

INSTALLATION INSTRUCTIONS
CHINA STAINLESS STEEL FLAGPOLE



<http://www.flagpole86.com>

Phone: (86) 592 5076211 | Fax: (86) 592 5133727

info@flagpole86.com

1. UNLOADING

Before unloading, please use hardboard or other soft materials as matting, and put the poles lightly and maintain level off.

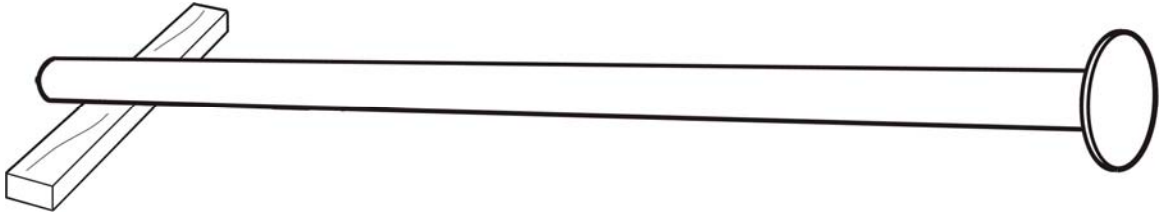

2. PREPARATION

Remove all wrapping materials and place unwrapped pole on cribbing or other wood support on ground (preferably in a covered dry area).

If pole is multi section, carefully lay sections out in proper order, grouping poles with like match marks. Sections **MUST BE STRAIGHT & LEVEL** while sliding together.

3. WELDING

Weld the sectional poles before installation. Polish, make it consistent with the original appearance.

The pole bottom with the base plate is welded before shipment.

4. RAISING

Don't use steel wire to tie with the surface of flagpole directly, use materials such as nylon rope, to prevent surface damage.

After raising flagpole, use vertical equipment to make correction from the positive and side, to reach vertical.

After correction, check whether they are consistent with the distance, and whether it is in a straight line or not.

DETAILS

INSTALLATION INSTRUCTIONS



SCREW
(4)



WASHER
(16)



HINGE NUT
(17)

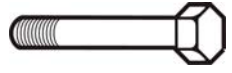

HINGE BOLT
(1)



FLAG STICK
(1)

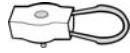

HOOK WITH SCREW
(1)

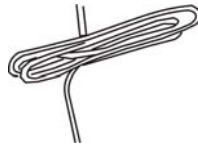

HALYARD
(1)



HOOK
(2)



COUNTERWEIGHT BEAD
(1)

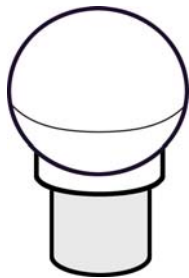

BALL TOP
(1)

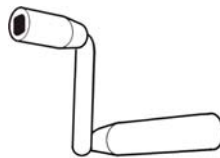

HANDLE
(1)

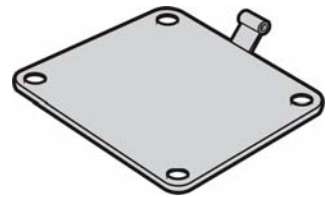

BASE PLATE
(1)

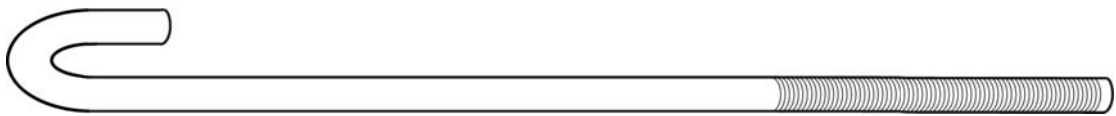

ANCHOR BOLTS
(4)

Before installation, lay all flagpole components out. Identify parts and place them along the pole.

When needed, clean the flagpole using hot water and soft soap. Use car wax to maintain the finish.

① FOUNDATION

INSTALLATION INSTRUCTIONS

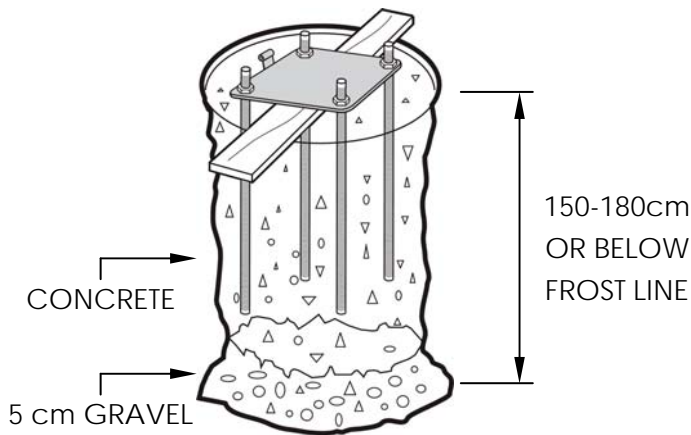

HOLE PREPARATIONS

1. Dig hole according to chart recommendation. If the ground is soft or sandy, increase the diameter of the hole.
2. Fill bottom 5 cm of hole with crushed stone.

HOLE DIMENSIONS



FLAGPOLE	6m	8m	10m	12m	14m	16m	18m	20m
Diameter (cm)	80	80	100	100	100	100	100	100
Depth (cm)	100	100	120	120	150	150	150	150

** Recommended dimensions for normal ground conditions.*

ASSEMBLING GROUND SET

1. Secure lower hinge plate to anchor bolts (A) by first threading down bottom hinge nuts (C), placing over hinge plate and securing top hinge nuts.
2. Once both elements complete, fill hole with concrete. When inserting ground set, make sure hinge bolt is in a position to allow for raising and lowering clear of obstruction.
3. Press ground assembly into centre of hole. Keep lower base plate above concrete with the assistance of wooden plank. Using a spirit level, check for levelness.

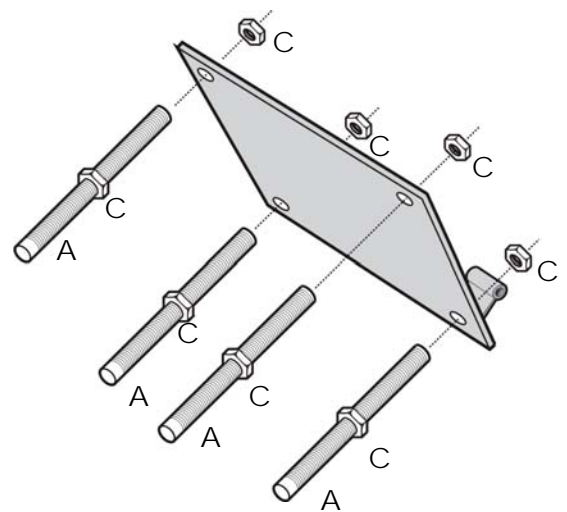

② FINIAL AND HALYARD

INSTALLATION INSTRUCTIONS

1. Thread halyard through revolving truck and fasten truck to top of flagpole using 4 supplied screws (A).
2. Tie the halyard to the hook (B).
3. Fix hook (C) to hanging stick (E).
4. Slip counterweight (D) over pole and tie to end of hanging stick (E).

When no flag is attached to the flagpole, make sure that counterweight sits at the very top of the flagpole.

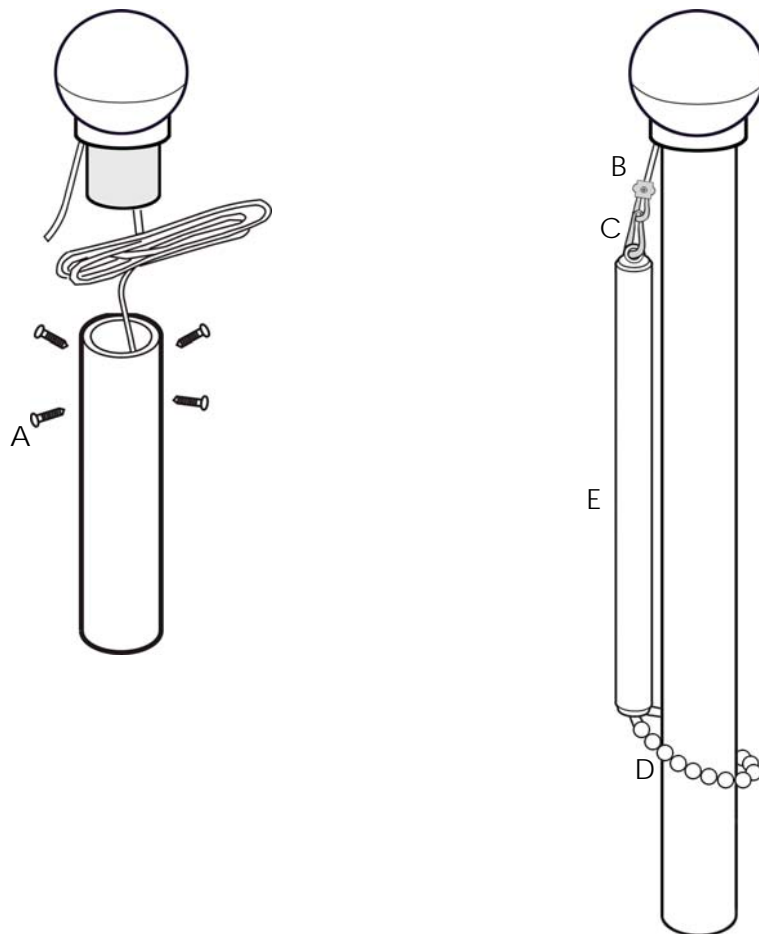

③ RAISING THE FLAGPOLE

1. When the concrete is firmly set, the flagpole can be raised. Bring base of flagpole to lower base plate, thread lower hinge nuts (H) and washers (G) onto anchor bolts 45 mm of exposed rod. Fasten hinge bolt (F), joining lower hinge base and flagpole base together.
2. Raise the flagpole. Place washers (G) and top hinge nuts (H). Through slight adjustments to hinge nuts, pole can be re-leveled. DRAW TIGHT.

NOTE: After several weeks, check that top nuts have stayed tight and tighten as required.

